

Clutch servo

Suitable for: Renault

Art. no.: 6.43006

replaces Kongsberg: 629300AM

Product Link: <https://dtpi.de/6.43006>



www.dt-spareparts.com - Art. 6.43006



360° view

The clutch servo 6.43006 consists of about 80 individual parts and is characterised by its high surface finishing in the wear-relevant internal running surface. This refined roughness is achieved through a special processing procedure and ensured through intensive quality controls.

Hereby the servo provides above-average results with regard to performance and service life. The use of the correct liquid, which is indicated on DT Spare Parts clutch servos, is paramount for this. Other features are the light design and the wear indicator through which the clutch wear can also be visually checked.

Further links

Similar articles from the product range of the brand DT Spare Parts

Note: Accessories are listed on the respective article detail page in the Partner Portal.

Tips & tricks

Before the new clutch servo is put into operation, the operating system should be monitored for impurities. If the equipment is in order, the system has to be vented. The correct medium must be used, as equipment that is not approved can damage the gaskets. The operating axle must be installed in accordance with the vehicle manufacturer's provisions insofar as they are provided.

Dependent on the type of vehicle, the wear values must be reset on the control unit after exchange. Additionally, a teach-in-process must be carried out in order to adjust the servo to the clutch system. The clutch servo must only be operated with full compressed air support in order to prevent a defect among the internal components through overstress.

Structure of the clutch servo

1. Pneumatic cylinder
2. Hydraulic cylinder
3. Cover
4. Boot
5. Piston rod
6. Servo piston
7. Compressed air connection
8. Hydraulic connection
9. Control valve
10. Wear indicator

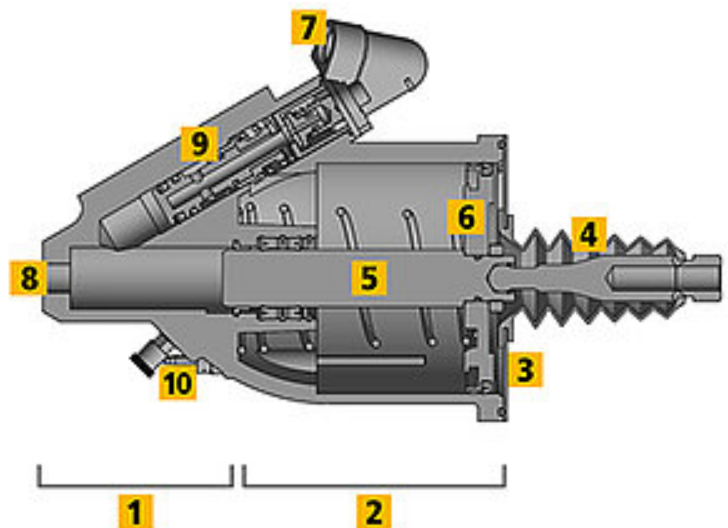

[Request article or order in Partner Portal](#)

DT Spare Parts

The brand DT Spare Parts from Germany provides a complete range of vehicle parts and accessories with a 24 month guarantee – no matter whether for trucks, trailers, buses, transporters or further applications, e.g. cars, agricultural vehicles, construction vehicles, marine or industrial applications. The guaranteed brand quality is achieved through the consistent product optimisation and relentless quality assurance within the framework of the Diesel Technic Quality System (DTQS).

More info: www.dtqs.de